



CO-T Thermocouple temperature transmitter

DESCRIPTION

CO-T transmitter is a **thermocouple** temperature transmitter into a **4-20 mA (or 20-4 mA)** electrical signal at adjustable microprocessor for K, J, T and N thermocouples temperature. It allows to convert variations of temperature reported by a thermocouple sensor for a measuring range going from **-200 to +1300 °C** in electric linear signal at 2 wires in the **4-20 mA** range. The configuration of the transmitter is simply made through a configuration button. It is also possible to use the **LCC101** software configuration to configure the transmitter. A led warns when an alarm situation appears (out of range or short-circuit). The transmitter is protected against inversions of polarity and has been designed to be placed in **DIN B** head probe.

DIMENSIONS (mm)

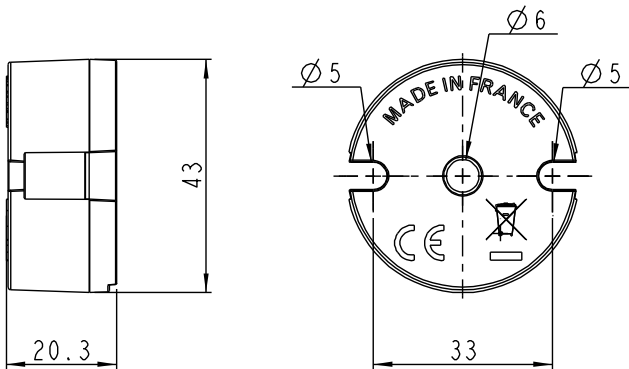

OUTPUT CURRENT WITH RELATION TO TEMPERATURE

(on the range from 0 to +100 °C)

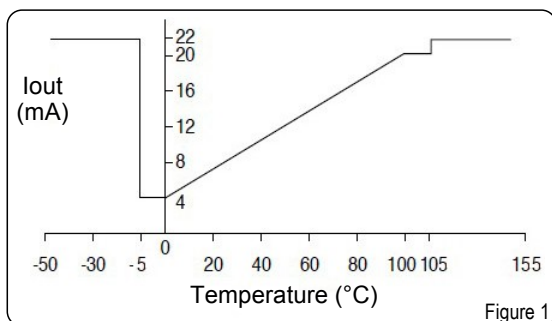

TECHNICAL FEATURES OF THE TRANSMITTER

(at 20 °C and for a power supply voltage of 24 Vdc)

• Input

Sensor	K, J, T and N thermocouples
Linearisation	EN 60584-1-2
Measuring range	From -200 to +1300 °C
Default range	From 0 to +1000 °C
Minimum measuring range	25 °C
Speed conversion	2 measurements per second
Accuracy	±0,5 °C or 0,04 % FS + 0,04 % of reading
Sensitivity to variations of ambient temperature	0,025 °C / °C
Sensitivity to variations of voltage supply	2 µA / V
Storage temperature	From -40 to +80 °C
Operating temperature	From -30 to +70 °C

• Output

Output	4-20 mA (or 20-4 mA), 22 mA in case of programming error or temperature out of range* (fig1)
Resolution	2 µA
Power supply voltage	9-30 VDC (protection against inversions of polarity)
Load resistance	$R_{Lmax} = \frac{V_{dc} - 3}{0,022}$ => $R_{Lmax} = 680 \Omega @ V_{dc} = 24 V_{dc}$
Red led	Lights up during the programming phase and when the measured temperature is outside the set range or in case of short-circuit

* if the measured temperature T is outside the set range T1...T2 (T1<T2), the transmitter maintains 4 mA for T<T1 for a dead band of 5 °C and 20 mA for T>T2 for a dead band of 5 °C before going into error status at 22 mA.

CONNECTION

Figure 2 shows the wiring diagram of the transmitter in the current loop. A device can be introduced in the current loop such as a display, a controller or a data logger.

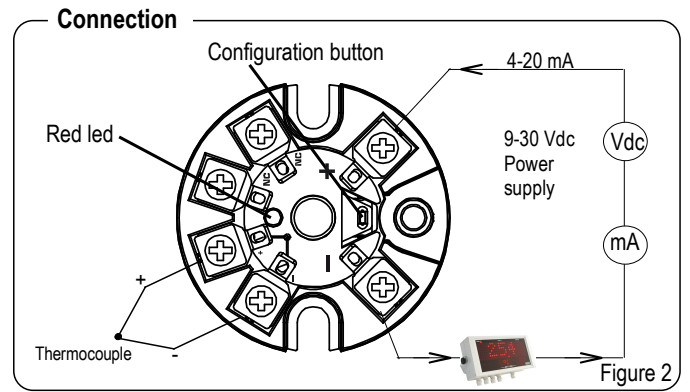

CONFIGURATION

- Select the thermocouple type: this action is only possible with **LCC101** software.

→ The default configuration is the following: thermocouple type K with a temperature range from 0 to 1000 °C.

It is possible to set a different measuring range using the following accessories:

- ① Continuous power source 9-30 Vdc
- ② Precision ammeter with minimum range from 0 to 20 mA.
- ③ Voltage generator from 0 to 50 mV

Procedure:

- Connect the transmitter to configure to the power supply, to the ammeter and to the voltage generator then make a long press on the configuration button. The led blinks twice during the push. When the blink becomes faster, release the button: programming mode is active.

a – Configuration of T1 point

- Led blinks one time at regular intervals: set the equivalent voltage to the required temperature for 4 mA output.
- Validate the instruction with a brief press on the programming button. Led stays on then blinks 4 times quickly: temperature for 4 mA output is recorded.

b – Configuration T2 point

- Led blinks two times faster at regular interval: set the equivalent voltage to the required temperature for 20 mA output.
- Validate the instruction with a brief press on the programming button. Led stays on then blinks 4 times quickly: temperature for 20 mA output is recorded.

In case of error whilst programming, if temperature is out of range or in alarm situation, led blinks 6 times quickly.

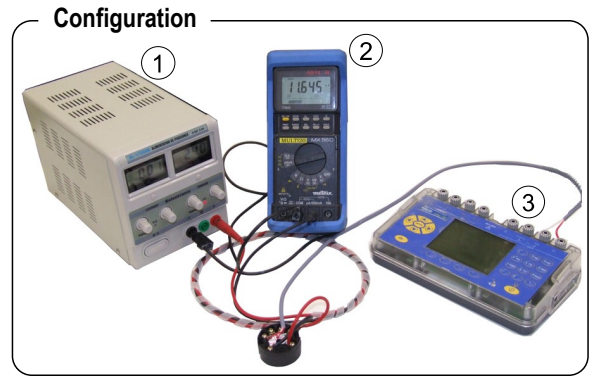

Programming scheme

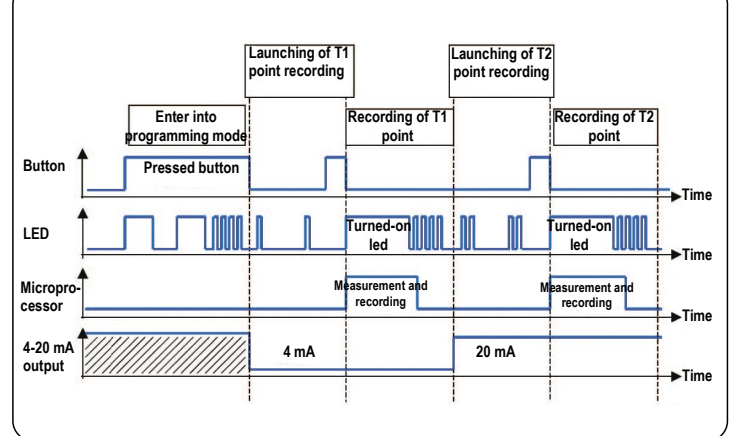

TEMPERATURE / VOLTAGE CORRESPONDENCES FOR K AND J THERMOCOUPLES AS PER NF EN 60584-1 STANDARD

°C	mV
-200	-5.891
-150	-4.913
-100	-3.554
-50	-1.889
0	0.000
50	2.023
100	4.096
150	6.138

°C	mV
200	8.138
250	10.153
300	12.209
350	14.293
400	16.397
450	18.516
500	20.644
550	22.776

°C	mV
600	24.905
650	27.025
700	29.129
750	31.213
800	33.275
850	35.313
900	37.326
950	39.314

°C	mV
1000	41.276
1050	43.211
1100	45.119
1150	46.995
1200	48.838
1250	50.644
1300	52.410

} Only for K thermocouple

www.kimo.fr

Distributed by :



EXPORT DEPARTMENT

Tel : + 33. 1. 60. 06. 69. 25 - Fax : + 33. 1. 60. 06. 69. 29

e-mail : export@kimo.fr