

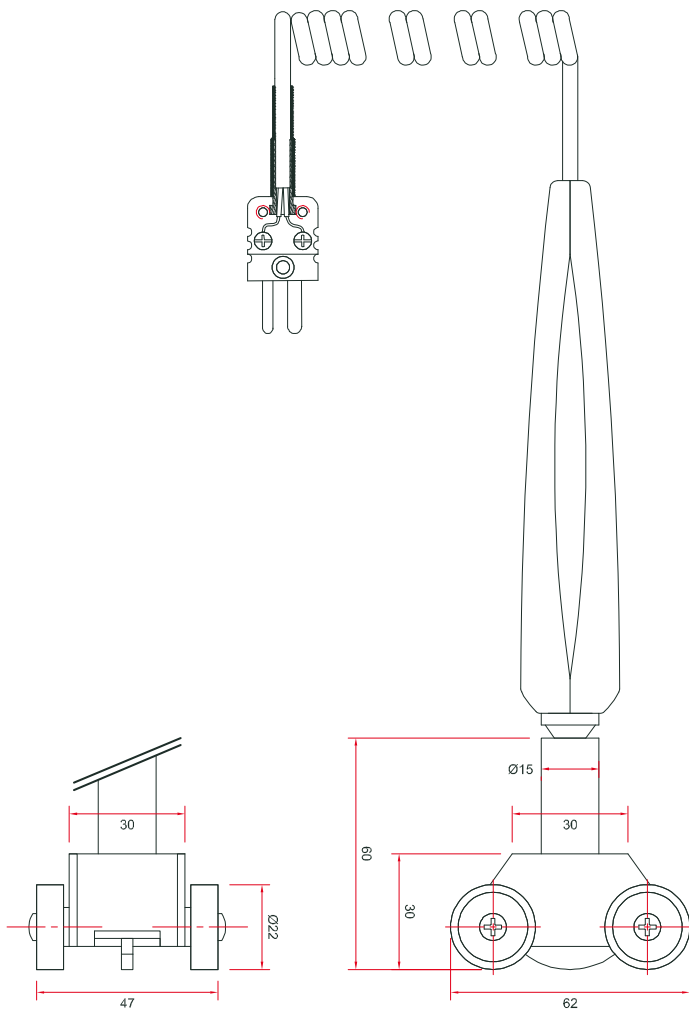

K thermocouple temperature sensor for measurement of surface with moving parts

SFCSM K

DIMENSIONS



PROBE FEATURES

- Thermocouple type K.
- Measuring range **from -40 °C to +500 °C**
- Response time very fast.

TECHNICAL FEATURES

Working temperature	From -40 °C to +500 °C (only for the trolley)
Accuracy* for class 1	See "Tolerances" table
Mounting of welding	Insulated hot welding in standard
Storage temperature	From -20 °C to +80 °C
Handle	ABS, 141 mm length, from -40 °C to +85 °C
Output	By PVC coiled cable, 200 mm length 1800 mm length stretched Temperature maxi 105 °C Male miniature connector (in standard)

TOLERANCES* OF THE PROBE

As per IEC 584-3 norm

TC	MEASURING RANGE CLASS 1	TOLERANCE
K	From -40 °C to +500 °C	From -40 °C to +375 °C ± 1.5 °C From 375 °C to 500 °C ± 0.004 x T°abs

* Performed in laboratory conditions, the above accuracies mentioned in this document will be guaranteed, provided that you use the calibration compensation data or identical calibration conditions.

www.kimo.fr

Distributed by :



EXPORT DEPARTMENT
Tel : + 33. 1. 60. 06. 69. 25 - Fax : + 33. 1. 60. 06. 69. 29
e-mail : export@kimo.fr